

Apollo Standard Port, Full Port & One Piece Flanged Ball Valves Installation, Operation, & Maintenance Manual

<p><u>Introduction</u></p> <p>This manual presents guidelines for the Installation, Operation and Maintenance of manual and automated Apollo standard port, full port & one piece, end entry flanged ball valves 1-1/2 inch and larger.</p>	<ul style="list-style-type: none"> ▪ Level of training, experience or ability of users should be at least that of trained and skilled maintenance personnel or technicians.
<p><u>Storage & Protection</u></p> <p>Valve should be stored in its original shipping container until just prior to installation with any protection means in place and protected from the environment or any other potentially damaging effects. Valve should be properly supported and secured before moving to prevent possible damage to valve, property or harm to personnel.</p>	<p><u>Cautions</u></p> <p>Reference Form No. I437800.D</p>
<p><u>Limitations</u></p> <ul style="list-style-type: none"> ▪ Conditions supporting no greater than Category III valves. Valves are not to be used in safety functions such as safety loops or separating incompatible fluids. ▪ For gases and liquids in Groups 1 & 2. ▪ In-line service only, not recommended for end of line service. ▪ Service to be compatible with the materials of construction. Prior to selection it is the user's responsibility to determine that the valve is appropriate for the intended application. Application not to allow corrosion $>.002$"/year (.05mm/year). ▪ The possibility of material deterioration in service and need for periodic inspections is the responsibility of the user. ▪ Mechanical supports are not to be welded directly to the valve, however may be fitted to the associated piping. ▪ It is the piping system designer's responsibility to implement appropriate protection measures to minimize reaction forces and moments, which result from supports, attachments, piping, etc. ▪ Laws of the state must be observed as they apply. ▪ In service inspections may be required by the national authorities of the country where the valve is installed. ▪ Some National/Local authorities may require periodic hydrostatic testing. ▪ Only use Conbraco replacement parts. ▪ On-off service only (not to be used for throttling). ▪ Valves are primarily intended for industrial use. 	<p><u>Installation</u></p> <p>Proper valve selection is the first step in any successful installation. Refer to an "Apollo Ball Valve Binder", where applicable for application guidance or contact your distributor or the factory for more detailed assistance.</p> <p><u>WARNING: All installations shall be provided with pressure relief devices in accordance with the requirements of the Pressure Equipment Directive 97/23/EC. Proper installation prior to initial operation is the user's responsibility. Furthermore where an additional hazard can occur due to valve exposure to fire or other unexpected external heat source, a supplemental pressure relief device shall be installed to protect against excessive pressure. This device shall prevent the pressure from rising more than 21% above the maximum allowable working pressure.</u></p> <p><u>Pre-Installation Inspection</u></p> <p>Inspect the piping system prior to valve installation whenever possible, to insure that it has been properly flushed and cleared of construction and fabrication debris. The seating surfaces in soft seated valves are particularly susceptible to weld slag and sand blasting grit. Pipe scale, metal chips and other foreign materials should be avoided.</p> <p>Just prior to installation, remove each valve from its packing, install handle and other parts if shipped loose (see figure 1) and remove any end covers. Examine the flow bore for debris. All Apollo ball valves are shipped in the open position to prevent damage to the ball surface. Any grit or foreign matter must be removed. Do not install a damaged valve.</p> <p>It is also important to check for valve operation clearances. If necessary, valves can be installed at angles other than upright or vertical.</p>

Operation

Apollo valves are shipped with a nameplate securely fastened to the valve body and an attached warning tag. Information included on each is documented on the last page of this manual. Although each valve is thoroughly tested and inspected before it leaves the factory, nameplate and/or warning tag could be lost or destroyed during shipment or while in storage. If either is missing or not legible, contact your distributor or the factory for assistance before operating valve. **WARNING Provide means to monitor filling valve to prevent over pressurization and instability.**

Ball valves are intended to be on-off devices operating through 90° rotation of the stem. Operation is clockwise to close.

The most common service failures not related to the installation and start-up processes are:

- * Exceeding the operating temperature or pressure limits of the valve due to a process upset condition.
 - * A chemical attack on valve components due to either misapplication or changes in the service.
- Violating temperature and pressure limits can result in immediate valve failure where chemical attack or corrosion generally occurs gradually.

Maintenance

Preventive Maintenance Schedule

Automated valves generally see high cyclic duty. A regularly scheduled and documented preventive maintenance program needs to be established for this type of valve.

Initially, it is recommended that valves be inspected every 5,000 cycles for smooth operation and leak free performance. Thereafter, every 20,000 cycles should be sufficient.

Problems if they occur most frequently appear immediately following initial start-up or following a re-start after a shutdown period. Particular attention needs to be paid to valves and other critical equipment during these times. Once the system has stabilized and is in operation, fewer problems tend to occur.

Valve Adjustments

At some point in the service life of the valve, leakage may occur. This should be noted in the maintenance history

log of the valve. The stem packing was adjusted at the factory to provide a leak tight seal when the valve was new, but compaction can occur within these seals that may make re-adjustment necessary. Stem leakage should be stopped as soon as it is detected. On actuated valves, most mounting hardware allows access to the packing adjustment screws. If this is not the case, it may be necessary to remove the actuator to gain adequate access to make the packing adjustment.

Packing adjustment can be accomplished by turning the stem packing adjustment screws clockwise to the maximum torque shown in Table 1. **Caution: Never back off the stem packing adjustment screws when the valve is under pressure.**

Table 1: Stem Packing Adjustment Screw Torque

Valve Size ⁽¹⁾⁽²⁾			Torque ⁽³⁾	
mm	(in)		N-m	(in-lb)
40	(1-1/2)	SP	2,03	(18)
40	(1-1/2)	FP	5,09	(45)
50	(2)	SP		
50 - 65	(2 - 2-1/2)	FP	9,94	(88)
65 - 80	(2-1/2 - 3)	SP		
80 - 100	(3 - 4)	FP	17,40	(154)
100 - 150	(4 - 6)	SP		
150 - 200	(6 - 8)	FP	48,14	(426)
200 - 250	(8 - 10)	SP		
250 - 300	(10 - 12)	FP	86,11	(762)

(1) SP = Standard Port, FP = Full Port

(2) Nominal

(3) Increase adjustment screw torque's by 25% for valves with graphoil packing (-24 option)

Do not over tighten the adjustment screws. Over-tightening will result in excessive operating torque and shorten the packing's service life. If stem leakage continues, or operating torque becomes excessive, de-pressurize the valve and replace the stem seals.

Valves with high operating torque not resulting from stem seal over-tightening or valves, which have leakage by the seats, may have damaged seats or ball surfaces. These valves should be de-pressurized, disassembled, and inspected for damage.

Valve Overhaul

As part of planned maintenance or as a result of a problem that cannot be adjusted away, a valve may require a complete overhaul. Due to the uncomplicated design of the Apollo flanged ball valves this can easily be

accomplished.

The first step is to contact your distributor to acquire an appropriate rebuild kit. These kits typically contain a complete set of seats, seals, and gaskets. If ball or stem damage is suspected, it is wise to order these parts when the seal kit is purchased. Most of these items will be in stock on your distributor's shelves. To properly order spare parts, you will need the valve model number as shown on the nameplate.

Disassembly

- Once the spare parts are on hand, the first step in the valve disassembly is to isolate the valve from line pressure. **WARNING do not attempt to work on any valve under pressure, and depending on the service, valve surface temperature may be hot, use proper protective gear to protect against burns. Also provide safe means for uncontrolled release of fluid.**
- Using an adjustable wrench, valve lever, or properly sized open end wrench, rotate the stem until the valve is in the one half open, one half closed position. Be careful not to damage the stem. This will allow any cavity pressure to be released into the pipeline. Place the valve in the open position after this is done.
- Next, loosen each of the ANSI flange nuts approximately one turn only initially. This will allow a second chance for any cavity pressure stored within the valve to be released. Leakage may occur outside of the pipeline.
- Before removing the ANSI flange bolting, take precautions to assure the safety of maintenance personnel. Make sure the valve and piping system are properly stabilized.
- Carefully remove the ANSI flange bolting. Take precautions not to scar the ANSI raised face surface when removing the valve from the piping system. Reinstall the raised face protectors supplied with the valve if they are available.
- Next, remove the lockplate, lever, external grounding spring, stem packing adjustment screws and the packing gland. Do not attempt to remove the stem packing at this time.
- **Standard & Full Port only** The next step is to remove

the body bolting nuts. Properly secure the valve before attempting to remove the body bolting nuts. It is not necessary to remove the body bolting studs.

- **One Piece only** The next step is to remove the retainer from the valve body. Properly secure the valve before attempting to remove the retainer. See figure 3 for dimensions to be used in fabricating a retainer removal tool using a flat piece of steel.
- Next, lift the retainer away from the body and remove the body seal. Make sure the valve is in the closed position before attempting the removal of the ball. Once the ball is removed, the stem can easily be pressed down into the body and removed.
- Seat removal may require the use of a wood or sheet metal screw. If the seats cannot be vibrated or easily lifted from their pockets, thread the screw into the face of the seat taking care not to damage the seat pocket. Threading approximately 1/8" (3 mm) deep should be sufficient. The use of two opposing screws may be necessary.
- Finally, remove the stem packing using care not to scratch or scar the stem packing box.

Inspection

- Thoroughly clean all the components in preparation for inspection.
- Inspect stem packing contact surfaces for scratches and pits. If either of these is apparent and can be removed with #120 or finer grit emery cloth, body replacement will not be necessary. Deep scratches running down the side of the packing gland or excessive pitting will necessitate the replacement of the valve body.
- Inspect the ball and seat pockets in the same manner, replace the ball if necessary.
- Inspect remainder of body & retainer interior for pitting or corrosion and replace either if excessive.
- Inspect all parts for wear due to erosion or abrasion and replace if excessive.

Note: Carbon steel component parts are Melonite treated and oil dipped to improve fatigue properties and increase wear and corrosion resistance.

Reassembly

- Begin the re-assembly process by cleaning each of the component parts with a clean towel or cloth.
- First, install the body side seat. Use a light grease or oil on the seats if the system permits.
- Place the stem bearing on the stem, and insert the stem into the valve body stem bore. Place the flats on top of the stem perpendicular to the pipeline.
- Place the internal grounding spring on the stem and carefully insert the ball into the body and install the body seal.
- ***Standard & Full Port only*** Insert the retainer seat and place the retainer on the body. The ANSI flange bolting will always straddle the valve centerlines. See Figure 1. Loosely assemble the body bolting nuts.
- ***One Piece only*** Insert the retainer seat and thread the retainer into the body. See Figure 2.
- Reinstall the stem packing, packing gland, gland plate, and stem packing adjustment screws in the order given. Do not over-tighten the stem packing adjustment screws. Refer to the maintenance section, Table 1, for torque requirements.
- ***Standard & Full Port only*** Torque the body bolts to the torque given in Table 2.
- ***One Piece only*** Torque the retainer to the torque's given in Table 3.
- Install the lever or actuator as applicable.

Table 2: Body Bolting Torque

Class	Valve Size ⁽¹⁾⁽²⁾			Torque	
	mm	(in)		N·m	(ft·lb)
150	40 - 50	(1-1/2 - 2)	FP	16,27	(12)
	65 - 80	(2-1/2 - 3)	SP		
150	80	(3)	FP	40,68	(30)
	100	(4)	SP		
150	100	(4)	FP	81,36	(60)
	150	(6)	SP		
150	150	(6)	FP	135,60	(100)
	200	(8)	SP		
150	200	(8)	FP	216,96	(160)
	250	(10)	SP		
150	250	(10)	FP	332,22	(245)
150	300	(12)	FP	481,38	(355)
300	40 - 50	(1-1/2 - 2)	FP	27,12	(20)
	65	(2-1/2)	SP		
300	65	(2-1/2)	FP	40,68	(30)
	80	(3)	SP		
300	80	(3)	FP	81,36	(60)
	100	(4)	SP		
300	100	(4)	FP	135,60	(100)
	150	(6)	SP		
300	150	(6)	FP	216,96	(160)
	200	(8)	SP		
300	200 - 250	(8 - 10)	FP	481,38	(355)
	250	(10)	SP		
300	300	(12)	FP	678,00	(500)

Table 3: Retainer Torque

mm	Valve Size ⁽¹⁾⁽²⁾		Torque	
	(in)		N·m	(ft·lb)
40	(1-1/2)	SP	278	(205)
50	(2)	SP	624	(460)

(1) SP = Standard Port, FP = Full Port

(2) Nominal

Final Adjustments

Cycle the valve from open to close several times to verify free operation. Occasionally, after testing or initial start up, a minor body or stem packing leak may occur. Adjust as necessary.

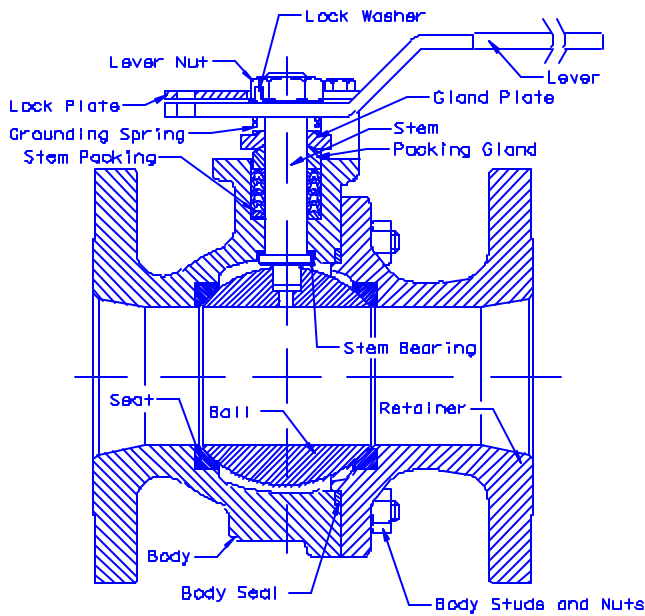

Figure 1: Typical Standard Port Valve Assembly

NAMEPLATE
CE MARKING
NOBO NO.
MODEL
BALL/STEM
SEAT/PACKING
MANUFACTURING DATE
DESIGN CODE
DN – SIZE
PS – MAXIMUM ALLOWABLE PRESSURE @ 38°C
CWP @ 100°F
CONBRACO IND., INC. Made In U.S.A.
WARNING TAG
Carefully read the applicable Installation, Operation, & Maintenance Manual in its entirety before removing valve from shipping container. To obtain manual, download from http://www.conbraco.com/iom . DO NOT REMOVE TAG.

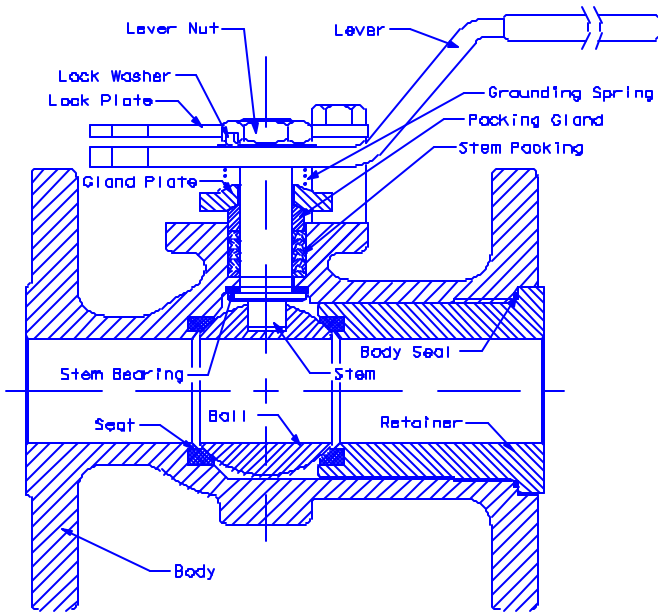

Figure 2: Typical One Piece Valve Assembly

Valve Size ⁽¹⁾⁽²⁾			A		B	
mm	(in)	SP	mm	(in)	mm	(in)
40	(1-1/2)	SP	34,3	(1.35)	9,14	(0.36)
50	(2)	SP	47,0	(1.85)	9,14	(0.36)

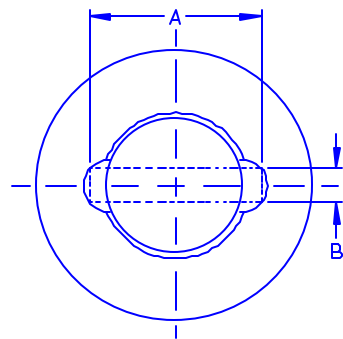

Figure 3: Retainer Removal Tool Dimensions

- (1) SP = Standard Port
- (2) Nominal